

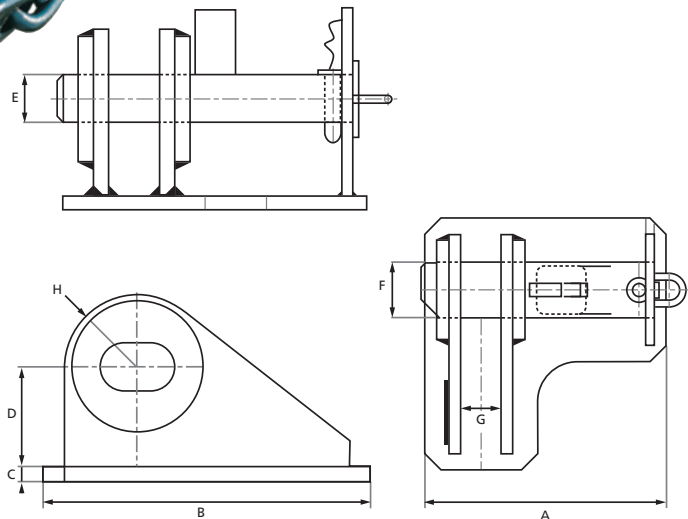

TOWING AND MOORING EQUIPMENT

# TOWING BRACKET

OCIMF-TYPE



Chain dia. mm	A mm	B mm	C mm	D mm	E mm	F mm	G mm	H mm	SWL tonnes
38	370	415	20	100	58	88	60	85	50
54	500	555	25	135	78	118	80	110	100
64	600	625	30	190	88	138	100	135	150
76	720	800	35	200	112	170	110	160	200
84	770	830	40	210	118	180	120	180	250
102	940	1120	45	260	130	210	150	225	320
114	1100	1180	50	300	162	250	170	235	380

Note: The measurements in tables may vary between different models. Sotra Anchor & Chain AS can not be hold responsible for any deviate between tables and delivered equipment.

**SOTRA ANCHOR & CHAIN AS**  
Gamle Vindenesvegen 11  
5363 Ågotnes, Norway

Tel.: (+47) 56 32 68 50  
E-mail: sales@sotra.net  
Web: www.sotra.net

